

FBs-CBEH2A

Multi-Function Ethernet Communication Board with Analog Input

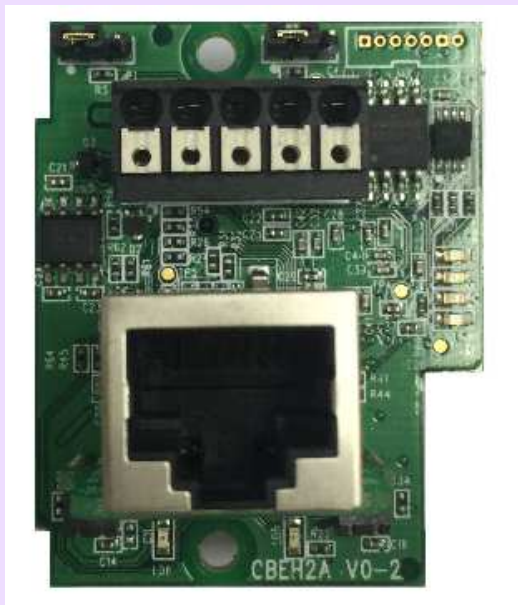

Introduction

FBs-CBEH2A is an Ethernet communication board mounted with analog input for FATEK FBs series PLC.

FBs-CBEH2A is one of the communication boards of FBs series PLC. Being an expansion board of Fatek PLC, there's no extra space required to accommodate it. With this board, FBs-PLC can act as a client or a server over the Ethernet and provide remote monitoring and diagnostic for PLCs.

While operating, it will utilize CPU communication port 1 and port 2. The working mode of port 1 is fixed as Fatek slave and can be used for programming or debugging while port 2 can be configured as Modbus-TCP server or client, or Fatek client.

FBs-CBEH2A also has built-in web server, which not only provides users with the ability to setup the configuration via web browser, but also gives user a way to customize his/her own web presentation that better fits what users need to monitor or control the PLC via internet.

Network configuration setup is a cumbersome and technical task for users during installation, especially with an dynamic IP address. The service callback function achieves remote access of any FBs series PLC without public IP address ,e.g. in a LAN. In most cases however, users don't need to perform configuration task while using this product.

When emergent events occur in the control system and a notification to the personnel away from the spot is required, the built-in Send Email function can be a solution. For quick response, SMS(Text) notification is also possible if the Email to SMS service is applicable.

For analog input it provides 2 channels of A/D inputs with 12-bit (coded in 12 bits) resolution. The Input signal types (voltage or current) can be selected by the field wiring.

Feature

- Multi-client accessible
- Modbus Server or Client operation mode
- Fatek Server and Client*1 operation mode
- IP-based access control
- Built-in web server
- Configuration setup via web browser
- User can create their own customized web pages by using the companion tool – EasyWebDesigner
- Service call back function , eliminate the cumbersome network setup task
- Network clock(SNTP) function, eliminate the periodic time-adjustment task
- Send Email function, with this function sending SMS message is possible via Email to SMS internet service.

Note 1: Fatek Client and Modbus function is exclusive (share the port2.)

Specification

Network Specification

Network interface-10/100BaseT

Network protocol -TCP/IP, ARP, ICMP

Application protocol -FATEK, Modbus/TCP, HTTP, DHCP, DNS, SNMP, SMTP, NetBIOS.

PLC interface- Port1,Port2

PLC interface speed- 307.2Kbps

Operating mode- Server and client

Storage capacity for Web server- 1.8M Byte

Max. customized web-page count- 100 pages

Web access authentication method- Password

Application ports- Modbus-TCP – 502, FATEK – 500, HTTP – 80 or configured by user.

Security mechanism – IP-based access control

Configuration methods- via Ethernet with utility program or Web-browser

Firmware update method – via Intranet

Analog Input Specification

Total Channels : 2 Channels

Resolution : 12 bits

Coding Format : 12 bits (0 ~ 4095)

Signal Resolution : 2.44mV(Voltage), 4.88uA(Current)

Registers Occupied : 2 Registers (D3964 · D3965)

Conversion Time : Updated each scan

Accuracy : $\pm 1\%$

Max. Absolute Input Rating :

0V~+13.2V(Voltage), 0A~26.4mA(Current)

Input Impedance : 100K Ω (Voltage), 125 Ω (Current)

Measurement Range : 0 ~ 10V(Voltage)

0 ~ 20mA(Current)

Common Specification

Indicator(s) : LINK/ACT(green LED), SPEED(red LED)

Internal Power Consumption: 5V, 250mA(Max. Load)

Operating Temperature : 5 ~ 55 °C

Storage Temperature : -25 ~ 70 °C

Screenshot of browser

Configuration setup for CBEH board

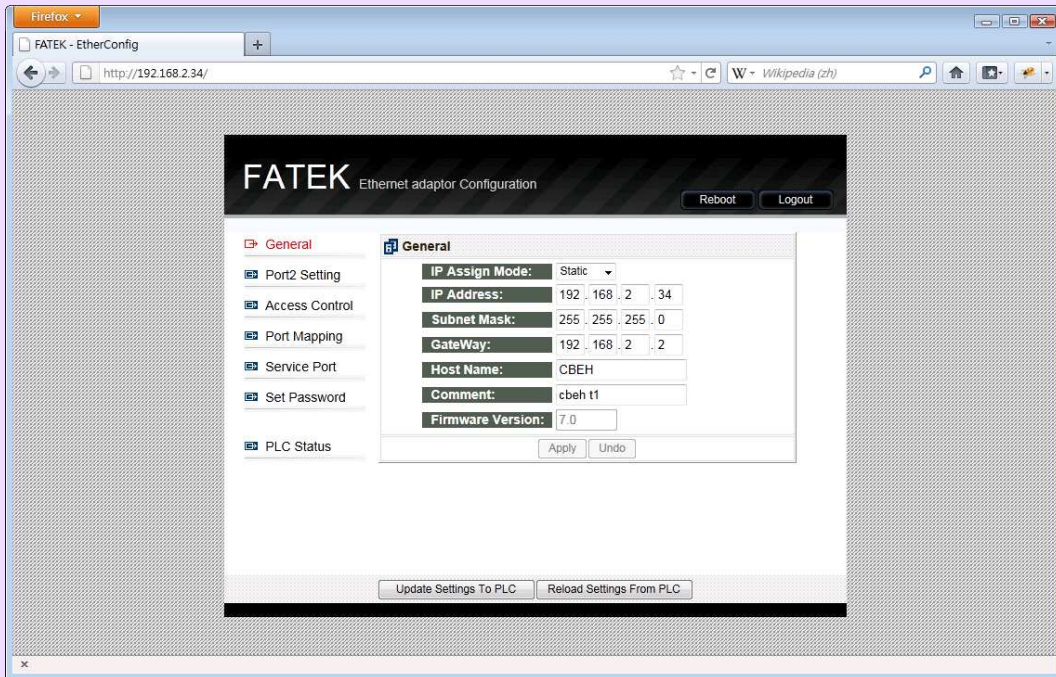

Customized Web-page created by using EasyWebDesigner tool



FBs- CBEH2A

Multi-Function Ethernet Communication Board with Analog Input

Wiring Diagram

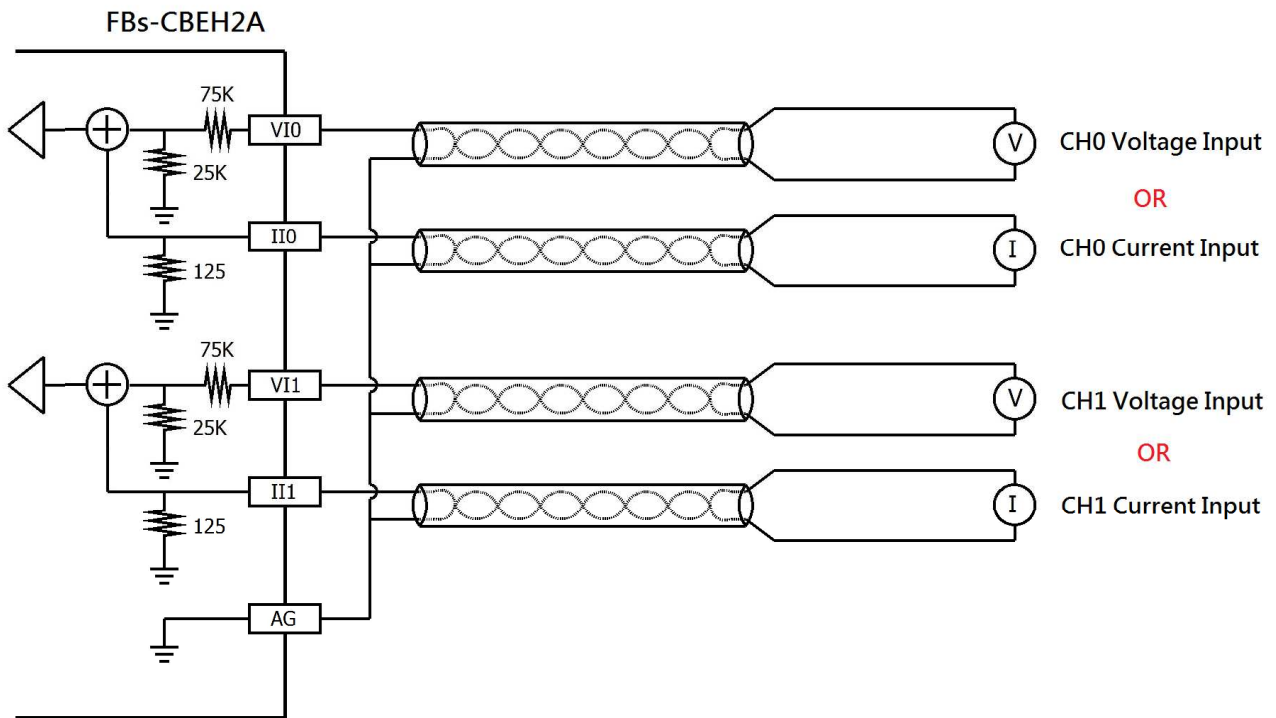

Characteristics Charts

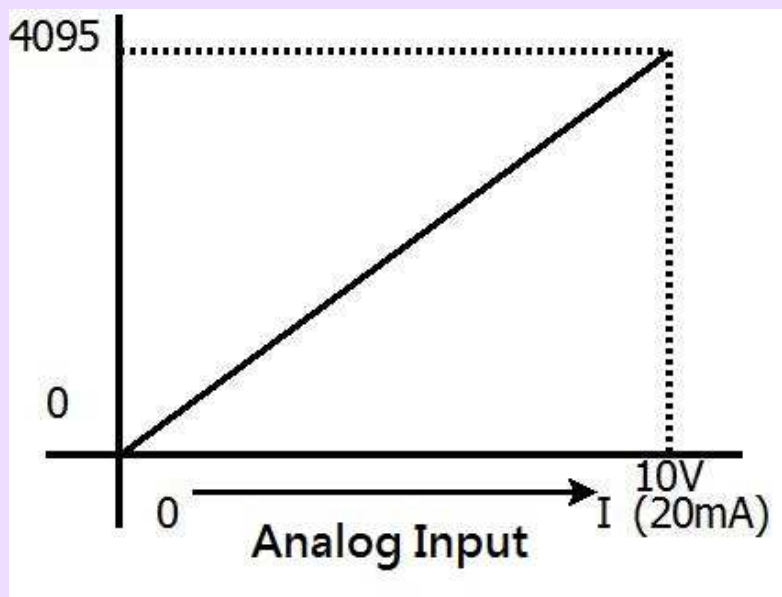

Registers allocation Map

	Channel No.	Mapped Register
Analog Input	CH0	D3964 (0 ~ 4095)
	CH1	D3965 (0 ~ 4095)